

Colposcopes and Stands



1E LED
1D LED
1DW LED
1DS LED

3MVC LED USB
3MVCS LED USB
3MVCW LED USB
3ML LED
3MLW LED
3MLS LED 1"
3MLS LED 1/2"

Instructions for Use

English



Publication details

Copyright ©LEISEGANG Feinmechanik-Optik GmbH 2013-2021.

All rights, delivery availability and technical changes reserved.

Issued by:

LEISEGANG Feinmechanik-Optik GmbH
Leibnizstrasse 32
D-10625 Berlin

Tel.: +49 30 319 009-0

Fax: +49 30 313 5992

E-Mail: sales.leisegang@coopersurgical.com

www.leisegang.de



Please read the instructions and information in the Instructions for Use carefully before using the device.

Contents

| | | |
|----------|--|-----------|
| 1 | Purpose..... | 5 |
| 1.1 | Intended use | 5 |
| 1.2 | Indications and field of application..... | 5 |
| 1.3 | Users and application environment..... | 6 |
| 1.4 | Patient population | 6 |
| 1.5 | Contraindications | 6 |
| 1.6 | Side-effects..... | 6 |
| 1.7 | Clinical benefits | 6 |
| 1.8 | Performance characteristics | 6 |
| 1.9 | General user information | 7 |
| 1.10 | Safety instructions..... | 7 |
| 1.10.1 | Meaning of symbols in these instructions..... | 7 |
| 1.10.2 | Meaning of symbols on the device and outer packaging | 7 |
| 1.10.3 | Precautions and safety information | 8 |
| 2 | Marketability | 10 |
| 2.1 | Manufacturer | 10 |
| 2.2 | Medical device and market placement..... | 10 |
| 2.3 | Warranty information | 10 |
| 2.4 | Reporting of serious incidents | 11 |
| 3 | Device description..... | 12 |
| 3.1 | Essential features | 12 |
| 3.2 | Colposcope..... | 12 |
| 3.3 | Stands | 15 |
| 4 | Technical data | 17 |
| 4.1 | General information | 17 |
| 4.2 | Power supply..... | 17 |
| 4.3 | Standard colposcopes..... | 18 |
| 4.4 | Photo/video colposcopes | 20 |
| 4.5 | Stands | 22 |
| 4.6 | 5-wheeled spider base..... | 23 |
| 4.7 | Model number | 24 |
| 4.8 | Electromagnetic compatibility..... | 25 |
| 5 | Transport and storage | 29 |
| 5.1 | Storage | 29 |
| 5.2 | Disposal of packaging material | 29 |

| | | |
|-----------|---|-----------|
| 6 | Operation..... | 30 |
| 6.1 | Preparing the colposcopy | 30 |
| 6.1.1 | Performing height adjustments..... | 30 |
| 6.1.2 | Performing a dioptric correction | 32 |
| 6.1.3 | Using a colposcope with glasses..... | 33 |
| 6.1.4 | Adjusting focus of eyepieces | 33 |
| 6.1.5 | Setting up working distance | 34 |
| 6.2 | Using a colposcope | 35 |
| 6.2.1 | Performing fine adjustments..... | 35 |
| 6.2.2 | Swing in the green filter | 36 |
| 6.2.3 | Adjusting magnifications | 36 |
| 6.2.4 | Determining the lesion size | 37 |
| 7 | Care, maintenance, inspection..... | 38 |
| 7.1 | Care and disinfection..... | 38 |
| 7.2 | Maintenance | 40 |
| 7.3 | Inspection, repeat tests..... | 40 |
| 8 | Repair | 40 |
| 9 | Customer service..... | 41 |
| 10 | Disposing of waste equipment..... | 42 |
| 11 | Glossary | 43 |
| 12 | Keyword index | 44 |

1 Purpose

1.1 Intended use

Leisegang colposcopes are used in gynecological examinations to provide enlarged, non-contact view of the outer female genitalia (vulva, vagina, portio) in the visible area. The colposcopes can also be used for enlarged, non-contact viewing of other external organs.

Leisegang photo/video colposcopes with an integrated or externally connected camera can also be used to document the findings.

Leisegang colposcopes are only used to aid in the diagnosis. In any case, further findings are to be consulted.

1.2 Indications and field of application

Leisegang colposcopes are used in gynecological examinations for magnified, non-contacting viewing of the external female genitalia (vulva, vagina, portio).

The device is intended for use in medical practices and clinics. The device is suitable for use in the operating theatre, but not for use in locations with MRI, CT, diathermy, RFID and electromagnetic security systems such as metal detectors.

The colposcope is intended for multiple uses. Chapter 7.1 *Care and disinfection* describes information about cleaning and disinfection.

Colposcopy – cytological findings:

- Suspicion of carcinoma
- Suspicion of low or high-grade dysplasia (deviation of the tissue structure from the normal image)
- Glandular atypia (glandular, possibly inflammatory epithelium atypia (deviations from the norm) that do not fulfil the criteria for dysplasia)
- Unclear findings from cytological smears (Pap smear, thin-layer cytology)
- Conspicuous smears in patients under immunosuppression (suppression of the body's own defenses), e.g. due to HIV infection or organ transplantation

Colposcopy – other findings:

- Confirmed infection with HPV (Human papillomaviruses: viruses that can cause cervical cancer)
- Contact bleeding (bleeding on mucosal contact, e.g. following sexual intercourse)
- Persistent vaginal discharge
- Macroscopic conspicuous cervix (changes visible to the naked eye)
- Cervical polyps (benign protrusions of the cervical mucosa)

1.3 Users and application environment

Users

| User group | Qualification | Activity |
|--|------------------|---------------------------|
| End user: Medical practitioners (physicians) | Gynecologist | Operation of the device |
| End user: Medical personnel | Medical training | Maintenance of the device |

Application environment

Leisegang colposcopes are only intended for use in rooms used for medical purposes.



Observe the local requirements for the electrical installation.

1.4 Patient population

The target patient population for application of Leisegang colposcopes includes adult and adolescent females, according to the judgment of the healthcare professional, when used at the anatomical sites as defined in the indications and field of application.

1.5 Contraindications

There are no known contraindications to the use of Leisegang colposcopes.

1.6 Side-effects

There are no known side-effects for the use of Leisegang colposcopes.

1.7 Clinical benefits

Leisegang colposcopes aid in the viewing of the outer female genitalia (vulva, vagina, portio) for abnormalities or further examination from inconclusive cervical cancer screening tests.

Leisegang colposcopes provide for non-contact view of the outer female genitalia or other external organs with no invasiveness and allow mobility or minimal interaction with physician.

1.8 Performance characteristics

When used according to the manufacturer's instructions for use, Leisegang colposcopes are intended to provide enlarged, non-contact view of the outer female genitalia (vulva, vagina, portio) or other external organs in the visible area with no invasiveness and allow mobility or minimal interaction with the physician.

1.9 General user information

This manual describes the intended use and operation of Leisegang colposcopes. Assembly and repair of the colposcopes are described in the assembly and repair manual.

Highlighting

| Highlighting | Function | Example |
|----------------|---|--|
| <i>Italics</i> | Reference to other sections or text passages | Please note the instructions as listed under <i>Chassis of colposcope head</i> . |
| Bold | Reference numbers for illustrations, for emphases | (1) |

1.10 Safety instructions

1.10.1 Meaning of symbols in these instructions

| Symbol | Meaning |
|--------|---|
| | Necessary information for the subsequent steps; information and tips. |
| | Safety notice "Caution" Warns of a danger that can lead to minor physical injuries or damage to property. |
| | Safety notice "Warning" Warns of a danger that can lead to serious physical injuries or to death. |

1.10.2 Meaning of symbols on the device and outer packaging

| Symbol | Meaning | Symbol | Meaning |
|--------|--|--------|--|
| | Conformity of the product with the provisions of the applicable EU directive (and national laws) | | Conformity of the product with US and Canadian safety requirements |
| | Manufacturer's address | | Date of manufacture |
| | Serial number of the product | | Model number of the product |
| | Transport and store dry | | Fragile; transport and store with care, do not drop |
| | Permissible humidity range during transport and storage | | Permissible temperature range during transport and storage |
| | Permissible pressure range during transport and storage | | Degree of protection; protection against the ingress of solid foreign bodies and water |

| Symbol | Meaning | Symbol | Meaning |
|--------|---|-------------------|---|
| | Transport and store with the arrows always point up | | Electromagnetic interference can occur in the vicinity of devices labelled this way |
| | Recycling of the packaging material | | Separate disposal of waste electrical-equipment |
| | Observe Instructions for Use | Colposcope | Generic device name in accordance with Global Medical Device Nomenclature (GMDN) |
| | Alternating current | | Direct current |
| | Protection class II | MD | Medical device |

1.10.3 Precautions and safety information

Read the following safety information carefully before installation and use:



- These instructions are part of the device and must be kept throughout the entire service life of the product.
- Keep these instructions available for reference and pass them on to the next user of the device.
- Observe the practically-oriented safety instructions in the relevant sections.
- Only use the colposcope with Leisegang stands and Leisegang accessories.
- Dirt and dust can impair the functionality of the device. Therefore protect the device when not in use with the dust protection cover supplied. Before covering the device, check that it is switched off.
- There is a risk of crushing when adjusting the height of the colposcope head and swing-o-matic stand. Therefore, observe the safety instructions in the relevant sections.
- The connecting tube of the colposcope must always be inserted at least 20 cm in the stand frame in order to ensure stability.
- Waste electrical and electronic equipment must not be discarded with household rubbish. Dispose of your old equipment in accordance with national requirements for separate disposal of waste or return your old device either to your supplier or Leisegang Feinmechanik-Optik GmbH.



- The device may only be operated in dry rooms without spray water.
- The device must not be operated in an oxygen-saturated environment.
- Set-up the device in a stable position.
- Do not roll the device over cables and tubes on the floor.
- Do not hang any additional objects on the device that are not expressly intended for this purpose.
- Do not lean against the device.
- Do not cover the cooling slots of the power supply or the cooling slots of the LED light source. This can cause overheating and damage to the device.
- Position the device in a way to allow easy access to the mains cable.
- Only pull the mains cable from the socket at the plug.

- Never remove the ferrite beads from the USB cables, since this may cause electromagnetic interference.
- Do not operate power supplies, mains cables, lamp cables or mains plugs with mechanical damage. Defective parts must be replaced by qualified, authorized specialist personnel. Contact your supplier in this regard.
- Do not undertake any modifications, as otherwise safe operation of the device is not guaranteed and all guarantee and warranty claims towards Leisegang Feinmechanik-Optik GmbH are void.
- Always unplug the device before changing the fuse and before cleaning the device.
- The power supply is not drip or splash-proof. The ingress of water results in an electric shock. For this reason, when cleaning the device ensure that no dripping water comes into contact with it. No infusion devices, e.g. infusion bags, bottles and lines may be installed above the colposcope that entail a risk of dripping.

2 Marketability

2.1 Manufacturer



LEISEGANG Feinmechanik-Optik GmbH

Leibnizstr. 32
10625 Berlin
Tel: +49 30 319009-0
Fax: +49 30 313 599-2
E-Mail: sales.leisegang@coopersurgical.com

2.2 Medical device and market placement

Leisegang colposcopes are class I medical devices according to Annex VIII, Chapter III of Regulation (EU) 2017/745 of 5 April 2017.

Leisegang Feinmechanik-Optik GmbH has demonstrated in a conformity assessment procedure according to this medical device regulation that Leisegang colposcopes and their accessories meet the basic safety and performance requirements of the regulation mentioned above.

The devices bear the CE mark to indicate compliance with these requirements. A copy of the Declaration of Conformity, which is issued under Annex IV of the Medical Devices Ordinance, can be enclosed with each colposcope delivered or sent to you if required, depending on the agreement.

2.3 Warranty information

Leisegang Feinmechanik-Optik GmbH can only guarantee the safety, reliability and performance of Leisegang colposcopes if the user observes the directions in these Instructions for Use.

The warranty covers the repair or replacement of defective parts insofar as these defects are based on the manufacture or the material.

The following actions void the warranty with immediate effect:

- Use of the colposcope other than for its intended purpose;
- Improper operation of the colposcope system
- Defects or equipment failures caused by improper operation or normal wear
- Device configurations that are not recommended by Leisegang;
- Modifications or repairs to the colposcope by unauthorized persons;
- Non-compliance with the applicable standards concerning electrical installations.

2.4 Reporting of serious incidents



PLEASE NOTE: If there is any suspicion that the use of the Leisegang colposcope is or could be causally related to a serious incident, details of the incident must be provided to CooperSurgical by telephone on +49 30 319009-0 or via the Email complaint-group.leisegang@coopersurgical.com and to the local Health Authority in your country.

A 'serious incident' means any malfunction or deterioration in the characteristics or performance of a device made available on the market, including use-error due to ergonomic features, as well as any inadequacy in the information supplied by the manufacturer and any undesirable side-effect, that directly or indirectly led, might have led or might lead to any of the following:

- a) the death of a patient, user or other person,
- b) the temporary or permanent serious deterioration of a patient's, user's or other person's state of health,
- c) a serious public health threat.

3 Device description

3.1 Essential features

All Leisegang colposcopes offer the following features:

- Convergent beam path; the beam paths converge at a working distance of 300 mm,
- 300 mm working distance,
- Green filter for viewing vessels (apart from angled devices)
- Dioptic correction through adjustable eyepieces,
- LED lighting with an illumination intensity of 45,000-52,000 lx¹ and a color temperature between 5,700-6,000 K,
- Leisegang colposcopes are designed for a service life of 10 years.

3.2 Colposcope

Front

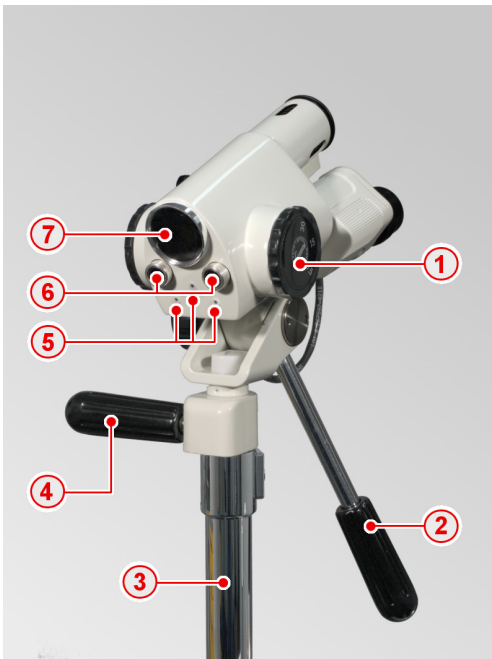

| | |
|---|---------------------------|
| 1 | Magnification changer |
| 2 | Horizontal adjustment |
| 3 | Connector tube |
| 4 | Vertical adjustment |
| 5 | Thread for mounting plate |
| 6 | Front lenses |
| 7 | Lamp optics |

Rear



| | |
|----|--|
| 8 | LED illumination unit |
| 9 | Green filter |
| 10 | Clamp nut for tilt adjustment (see appendix) |
| 11 | Lamp cable |
| 12 | Eyepieces |
| 13 | Prism bodies |

¹ 23,000-35,000 lx for colposcopes with magnification levels 3.75x/7.5x/15x

| Colposcope type plate | | |
|-----------------------|--|---|
| Model number | REF 3MVC - 121112 | Device name |
| Serial number | SN 00-000000 | CE mark |
| Manufacturer | Leisegang GmbH Leibnizstr. 32, D-10625 Berlin | Date of manufacture |
| | Input 4V, 20W | Input |
| | Rev. 1.1 | Separate disposal of waste electrical equipment |

Power supply



WARNING

Injury through electric shock

The use of a third-party power supply can result in an electric shock.
 ► The colposcope models listed above must only be operated with the stated power supplies!

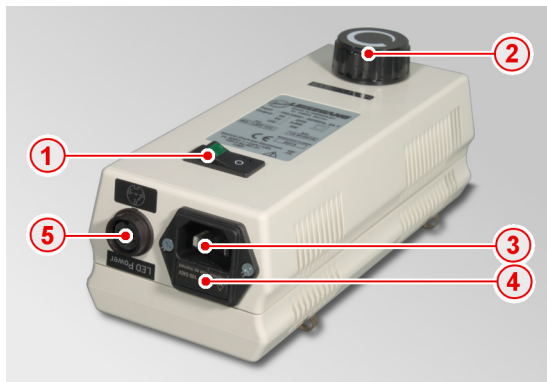

| | |
|---|---|
| 1 | On/off switch |
| 2 | Brightness control |
| 3 | Connection for the mains cable |
| 4 | Fuse holder |
| 5 | Connector socket with bayonet lock for the lamp cable |

Power supply type plate

| | | |
|---------------------------------|--|--|
| | POWER SUPPLY FOR COLPOSCOPE | Device name |
| Model number | REF B6400 / LED Y/C | |
| Serial number | SN 00-000000 | CE mark |
| Date of manufacture | 2015-01 | |
| Input | Input : 100-240V~ ,50/60Hz, 2A T | |
| Output | Output : 3.2V, 3A 5V, 600mA | Protection class II |
| | Leisegang GmbH Leibnizstr. 32, D-10625 Berlin | Manufacturer |
| | LEISEGANG Made in Germany | |
| | MEDICAL EQUIPMENT WITH RESPECT TO ELECTRICAL SHOCK; FIRE AND MECHANICAL HAZARD ONLY IN ACCORDANCE WITH AAMI/ANSI ES60601-1 AND CAN/CSA C22:2 | |
| Observe Instructions for Use | No. 60601.1:08 | Protection type |
| | 14MY Rev. 2.0 | Separate disposal of waste electrical |

3.3 Stands

Swing-o-matic stand



| | |
|---|--|
| 1 | Star knob screw |
| 2 | Spider base column |
| 3 | Clamp flange |
| 4 | Supporting ring with latch pin |
| 5 | Conical insert |
| 6 | 5-wheeled spider base with counterweight |
| 7 | Frame |
| 8 | Clamp nut for clamp head |
| 9 | Power supply |

Balance-o-matic stand



| | |
|----|--|
| 1 | Circular level |
| 2 | Column for balance-o-matic stand |
| 3 | Spring shaft |
| 4 | Clamp pair |
| 5 | Adjusting collar for tension spring |
| 6 | 5-wheeled spider base with counterweight |
| 7 | Conical insert |
| 8 | Frame |
| 9 | Clamp nut for clamp head |
| 10 | Power supply |
| 11 | Clamping lever |

Upright stand







| | |
|---|--------------------------|
| 1 | Clamp nut for clamp head |
| 2 | Power supply |
| 3 | Cable outlet |
| 4 | Stand column |
| 5 | 5-wheeled spider base |

4 Technical data

4.1 General information

| Operational data | |
|--------------------------------------|--|
| Usage type | Not suitable for use in an oxygen-enriched environment |
| Operating mode | Suitable for continuous operation |
| Applied parts | The device has no applied parts that come into direct contact with the patient |
| Working distance | 300 mm |
| Environmental and storage conditions | |
| Ambient temperature | 10-45 °C |
| Relative humidity | 30-75%, non-condensing |
| Air pressure | 700-1,060 hPa |
| Storage | Dry, cool, protected against dripping water, non-condensing |

4.2 Power supply

| Power supply  B 6400 / LED Y/C | | |
|---|---|------------------|
| Input | 100-240 V ~ 2 A _{max} , 50/60 Hz | |
| Output | 3.2 V  3 A _{max} | |
| | 5 V  600 mA _{max} | |
| Protection against electric shock |  Protection class II | |
| Protection against the ingress of solid foreign bodies and liquids | IP 20 | |
| Integrated illumination | | |
| | With magnification | |
| | 3.75x/7.5x/15x | 7.5x/15x/30x |
| Light source | LED | |
| Power consumption | 10 W | |
| Illumination intensity E _v (at a distance of 300 mm) | 23,000-35,000 lx | 45,000-52,000 lx |
| Illuminated field diameter | 78 mm | 58 mm |
| Field of view diameter | 76/38/19 mm | 46/23/11.5 mm |

4.3 Standard colposcopes

1E LED



| | | |
|--|--------------------|---|
| Model | 1E LED | |
| Mechanical data | | |
| Weight | 2.75 kg | |
| Dimensions H x W x D | 605 x 135 x 205 mm | |
| Configuration | | |
| Magnification | 7.5x | – |
| | 15x | ● |
| | 30x | – |
| Dioptric correction (±7 diopter) | ● | |
| Horizontal and vertical fine adjustment | ● | |
| Green filter | ● | |
| 45° angled view | – | |
| Head tilt angle | 50° | |



| Model | | 1D LED ² | 1DW LED |
|--|------|---------------------|--------------------|
| Mechanical data | | | |
| Weight | | 3.00 kg | 3.10 kg |
| Dimensions H x W x D | | 605 x 135 x 205 mm | 640 x 135 x 245 mm |
| Configuration | | | |
| Magnification | 7.5x | ● | ● |
| | 15x | ● | ● |
| | 30x | ● | ● |
| Dioptric correction (±7 diopter) | | ● | ● |
| Horizontal and vertical fine adjustment | | ● | ● |
| Green filter | | ● | – |
| 45° angled view | | – | ● |
| Head tilt angle | | 50° | 50° |

² Also as 1DS LED (magnification: 3.75x/7.5x/15x)

4.4 Photo/video colposcopes

3ML LED



3MLW LED



| Model | 3ML ³ LED | 3MLW LED |
|--|----------------------|--------------------|
| Mechanical data | | |
| Weight | 3.90 kg | 4.05 kg |
| Dimensions H x W x D | 660 x 135 x 210 mm | 675 x 135 x 240 mm |
| Configuration | | |
| Magnification | 3.75x | – |
| | 7.5x | ● |
| | 15x | ● |
| | 30x | ● |
| Dioptic correction (±7 diopter) | ● | ● |
| Horizontal and vertical fine adjustment | ● | ● |
| Green filter | ● | – |
| 45° angled view | – | ● |
| Video camera, integrated | – | – |
| Video camera, external | ● | ● |
| DSLR camera (e.g. Canon EOS) | ● | ● |
| Head tilt angle | 45° | 45° |

³ Also as 3MLS LED 1" and 3MLS LED 1/2" (magnification: 3.75x/7.5x/15x)

3MVC LED USB



3MVCW LED USB



| Model | 3MVC LED USB ⁴ | | 3MVCW LED USB | |
|--|---------------------------|---|--------------------|--|
| Mechanical data | | | | |
| Weight | 3.25 kg | | 3.60 kg | |
| Dimensions H x W x D | 625 x 135 x 195 mm | | 630 x 135 x 245 mm | |
| Configuration | | | | |
| Magnification | 7.5x | ● | ● | |
| | 15x | ● | ● | |
| | 30x | ● | ● | |
| Dioptric correction (±7 diopter) | ● | | ● | |
| Horizontal and vertical fine adjustment | ● | | ● | |
| Green filter | ● | | – | |
| 45° angled view | – | | ● | |
| Video camera, integrated | ● | | ● | |
| Video camera, external | – | | – | |
| DSLR camera (Canon EOS) | – | | – | |
| Head tilt angle | 50° | | 50° | |

⁴ Also as 3MVCS LED USB (magnification: 3.75x/7.5x/15x)

4.5 Stands



Stands and spider bases are accessories for colposcopes (see appendix)



| Model | Upright stand | Swing-o-matic stand | Balance-o-matic stand |
|---------------------------------------|---|---------------------------------------|--|
| Mechanical data | | | |
| Weight (without spider base) | 1.75 kg | 5.00 kg | 7.90 kg |
| Weight (with spider base) | 26.75 kg | 30.00 kg | 32.90 kg |
| Dimensions H x W _{max} | 670 x 120 mm | 680 x 640 mm | 750 x 715 mm |
| Horizontal movement | – (rigid column) | freely rotating in a radius of 600 mm | freely rotating in a radius of 600 mm |
| Vertical movement | – (manually lockable) | – (manually lockable) | balanced zero-force-movement, lockable |
| Working height | 970-1090 mm (manually lockable) | 970-1090 mm (manually lockable) | 780-1200 mm (two-stage locking mechanism) |
| Configuration | | | |
| Chair mounting (right/left) | – | ● | ● |
| Assembly of the 5-wheeled spider base | only with lightweight 5-wheeled spider base (without counterweight) | ● | ● |

4.6 5-wheeled spider base



| | |
|-----------------|---|
| Model | Heavy 5-wheeled spider base |
| Weight | 25.00 kg (incl. counterweight) |
| Diameter | 750 mm |
| Castors | Universal castors for all floors, 5 lockable castors |

4.7 Model number

The model number (**REF**) comprises the following categories:

| | | Eyepiece view | | Magnification | | | Head adjustment | | Illumination | Camera interface | | | Chip size | | | | |
|-------|------------|---------------|---------------|---------------|-----------------|-------------------|-----------------|-----------|--------------|------------------|-----|----------|-----------|----------|------|------|----|
| Digit | | 1 | | 2 | | | 3 | | 4 | 5 | | | 6 | | | | |
| | Model name | Straight | 45° tilted | 1 15x | D 7.5/15/30x | S 3.75/7.5/15x | Fine | Only tilt | LED | -- | USB | Y/C NTSC | -- | 1/4 " | 1/3" | 1/2" | 1" |
| Code | XXX – | 1 | 2 | 1 | 2 | 3 | 1 | 2 | 1 | 0 | 1 | 3 | 0 | 1 | 2 | 3 | 5 |

| | | | | | | | | | | | | | | | | | |
|-----------------|------------------|----------|--|--|----------|--|----------|--|----------|--|----------|--|--|----------|--|--|--|
| Example: | 1D-121100 | 1 | | | 2 | | 1 | | 1 | | 0 | | | 0 | | | |
|-----------------|------------------|----------|--|--|----------|--|----------|--|----------|--|----------|--|--|----------|--|--|--|

The example shown reflects the model name for a model 1D LED device with the following features:

- Digit 1: Straight insight
- Digit 2: 7.5/15/30x magnification
- Digit 3: Fine adjustment for height, tilt and sharpness
- Digit 4: LED lighting
- Digit 5: Without camera interface
- Digit 6: Without chip

4.8 Electromagnetic compatibility

Leisegang colposcopes are intended for use in an environment that meets the electromagnetic specifications below.

Leisegang colposcopes have been designed to withstand the effects of electromagnetic interference (EMI) and meet the latest EMC standards. However, extremely high levels of electromagnetic energy (above the levels specified in IEC 60601-1-2) may still cause interference.

In order to reduce the risk of EMI, follow these recommendations:

- Do not turn on or use mobile communication devices, such as mobile two-way radios or mobile phones, in the proximity of the device. If the use of such equipment is required, please observe the information on 'recommended distance' in the following tables.
- In the event of unexplained EMI, check if there are any transmitters, such as radio or TV stations, located nearby. Either the location of the device may need to be changed or shielding between the transmitter and the device may need to be installed.
- We would like to point out that modification of the device or the addition of accessories or components could make the device more susceptible to the interference of high frequency waves.

Table 1:
Guidance and manufacturer's declaration - electromagnetic radiation

Leisegang colposcopes are intended for use in the electromagnetic environment specified below. The user of a Leisegang colposcope must ensure that the device is being operated in such an environment.

| Emissions test | Compliance | Electromagnetic environment - guidance |
|--|------------|---|
| RF emissions CISPR 11 | Group 1 | Leisegang colposcopes use RF energy only for internal functions. The RF emissions are therefore very low and are not likely to cause any interference in nearby electronic equipment. |
| RF emissions CISPR 11 | Class B | Leisegang colposcopes are suitable for use in all environments, including domestic establishments and those directly connected to the public low-voltage power supply network that supplies buildings used for domestic purposes. |
| Harmonic emissions IEC 61000-3-2 | Class A | |
| Voltage fluctuations/ flicker emissions IEC 61000-3-3 | Complies | |

Table 2:
Guidance and manufacturer's declaration - electromagnetic immunity

Leisegang colposcopes are intended for use in the electromagnetic environment specified below. The user of a Leisegang colposcope must ensure that the device is being operated in such an environment.

| Immunity test | IEC 60601 test level | Compliance level | Electromagnetic environment - guidance |
|--|---|--|--|
| Electrostatic discharge (ESD) | ±8 kV contact | ±8 kV contact | Floors should be wood, concrete or ceramic tile. If floors are covered with synthetic material, the relative humidity should be at least 30%. |
| IEC 61000-4-2 | ±15 kV air | ±15 kV air | |
| Fast electrical transients/bursts | ±2 kV for power supply lines | ±2 kV for power supply lines | The main power supply should correspond to that of a typical commercial facility or a hospital. |
| IEC 61000-4-4 | ±1 kV for input/output lines | ±1 kV for input/output lines | |
| Surge voltage | ±1 kV differential mode | ±1 kV differential mode | The main power supply should correspond to that of a typical commercial facility or a hospital. |
| IEC 61000-4-5 | ±2 kV normal mode | ±2 kV normal mode | |
| Voltage dips, short interruptions and voltage variations at power supply input lines IEC 61000-4-11 | <5% <i>UT</i> (>95% dip in <i>UT</i>) for 0.5 cycles | <5% <i>UT</i> (>95% dip in <i>UT</i>) for 0.5 cycles | The main power supply should correspond to that of a typical commercial facility or a hospital. If the user of a Leisegang colposcope requires continued operation during power mains interruptions, it is recommended that the Leisegang colposcope is powered by an uninterruptible power supply or a battery. |
| | <40% <i>UT</i> (>60% dip in <i>UT</i>) for 5 cycles. | <40% <i>UT</i> (>60% dip in <i>UT</i>) for 5 cycles. | |
| | <70% <i>UT</i> (>30% dip in <i>UT</i>) for 25 cycles | <70% <i>UT</i> (>30% dip in <i>UT</i>) for 25 cycles. | |
| | <5% <i>UT</i> (>95% dip in <i>UT</i>) for 5 seconds | <5% <i>UT</i> (>95% dip in <i>UT</i>) for 5 seconds | |
| Mains frequency (50/60 Hz) magnetic field IEC 61000-4-8 | 30 A/m | 30 A/m | The magnetic fields of mains frequency should be within a range that is characteristic for a typical commercial environment or in the environment of a hospital. |
| Note: <i>UT</i> is the AC voltage prior to the application of the test level. | | | |

Table 3:
Guidance and manufacturer's declaration - electromagnetic immunity

Leisegang colposcopes are intended for use in the electromagnetic environment specified below. The user of a Leisegang colposcope must ensure that the device is being operated in such an environment.

| Immunity test | IEC 60601 test level | Compliance level | Electromagnetic environment - guidance |
|-------------------------------|--|--------------------|--|
| Conducted HF IEC 61000-4-6 | 3 V _{eff} 150 kHz to 80 MHz | 3 V _{eff} | Portable and mobile RF communications equipment should not be used closer to parts of the Leisegang colposcope, including cables, as specified in the recommended distance. This is based on the valid formula for the frequency of the transmitter. Recommended distance: $d = [3.5 / 3] \sqrt{P}$ $d = [3.5 / 3] \sqrt{P}$ 80 MHz to 800 MHz $d = [7 / 3] \sqrt{P}$ 800 MHz to 2.5 GHz In this case <i>P</i> is the maximum output power rating of the transmitter in watts (W) according to the manufacturer of the transmitter; <i>d</i> is the recommended distance in meters (m). The field strength of the fixed RF transmitters, as determined by an electromagnetic site survey ^(a) should lie below the compliance level in each frequency range ^(b) . Interference may occur in the vicinity of equipment marked with the following symbol:  |
| | 6 V _{eff} ISM band between 150 kHz and 80 MHz | 6 V _{eff} | |
| Radiated RF IEC 61000-4-3 | 3 V/m and 10 V/m 80 MHz to 2.7 GHz | 3 V/m and 10 V/m | |
| Note 1: | At 80 MHz and 800 MHz, the higher frequency applies. | | |
| Note 2: | These guidelines may not apply in all situations. Electromagnetic propagation is affected by absorption and reflection from structures, objects and people. | | |
| a) | The field strength of fixed transmitters, such as base stations for (mobile/cordless) phones and public land mobile radios, amateur radio, AM and FM radio stations and TV transmissions can, in theory, not be predicted accurately. In order to assess the electromagnetic environment due to fixed RF transmitters, a factory-made electromagnetic site survey is recommended. If the measured field strength in the location, in which the Leisegang colposcope is being operated, exceeds the above-mentioned RF compliance level, particular attention must be paid in order to guarantee a normal operation of the Leisegang colposcope. If an incorrect operation is observed, additional measures may be required, such as the realignment or relocation of the Leisegang colposcope. | | |
| b) | Above the frequency range of 150 kHz to 80 MHz, the field strength should be less than 3 V/m. | | |

Table 4:
Recommended distance between the portable and mobile RF communication device and a Leisegang colposcope - valid for equipment and systems that are not life-sustaining

Leisegang colposcopes are for use in an electromagnetic environment in which radiated RF interference is monitored. The customer or user of a Leisegang colposcope can help prevent electromagnetic interference by maintaining a minimum distance between the portable/mobile RF communications device (transmitter) and the Leisegang colposcope as recommended below; this minimum distance is determined by the maximum output power of the communications device.

| Maximum output power of transmitter W | Distance according to frequency of transmitter m | | |
|---------------------------------------|--|---|--|
| | 150 kHz to 80 MHz $d = [3.5 / 3] \sqrt{P}$ | 80 MHz to 800 MHz $d = [3.5 / 3] \sqrt{P}$ | 800 MHz to 2.5 GHz $d = [7 / 3] \sqrt{P}$ |
| 0.01 | 0.12 | 0.12 | 0.23 |
| 0.1 | 0.37 | 0.37 | 0.74 |
| 1 | 1.2 | 1.2 | 2.3 |
| 10 | 3.7 | 3.7 | 7.4 |
| 100 | 12 | 12 | 23 |

For transmitters rated at a maximum output power not listed above, the recommended distance d in meters (m) can be estimated using the equation applicable to the frequency of the transmitter, where P is the maximum output power rating of the transmitter in watts (W) according to the transmitter manufacturer.

Note 1: At 80 MHz and 800 MHz, the higher frequency applies.

Note 2: These guidelines may not apply in all situations. Electromagnetic propagation is affected by absorption and reflection from structures, objects and people.

5 Transport and storage

5.1 Storage



- If the boxes are stored for a longer period of time, attention needs to be paid that the environmental conditions are dry, cool and non-condensing. The boxes must be stored protected against dripping water.
- Store the boxes on the correct side, according to the inscription 'Top'.

5.2 Disposal of packaging material



The packaging is made from recyclable materials and can be recycled. Use the country-specific waste disposal system.



Keep hold of the original packaging for at least as long as the duration of the warranty period. If necessary, so that the device can be transported in a well protected manner. If the original packaging no longer exists, the packaging costs will be invoiced.

6 Operation

6.1 Preparing the colposcopy



The installation and initial start-up of the colposcope should only be performed by a qualified technician. Please contact your supplier.

Before starting the set-up, please check that the power cord is plugged in and that the power supply is turned on.

6.1.1 Performing height adjustments

The general working height is set during the assembly of the device. However, if needed, the height can be adjusted:

Swing-o-matic stand



CAUTION

Risk of crushing through weight

The stand is heavy and can cause crushing injuries if dropped.

- Hold the stand frame when adjusting the working height until the supporting ring is locked in place.

1. Hold the stand frame and pull out the latch pin of the retaining ring (1). Move the retaining ring to the desired height and release the latch pin into the appropriate hole (2):



2. Carefully put the stand frame back on.
 - The general working height is set.

Balance-o-matic stand

Release the locking lever, move the stand frame to the desired height and slide the locking lever back to hold position:

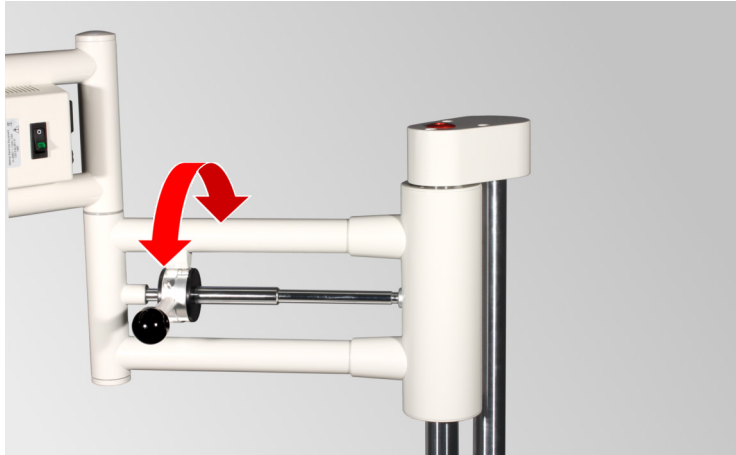

In the inactive setting or outside the working position the stand may be in the so-called "park position" (collapsed). Up and down movement should be avoided in this position, as otherwise damage to the supports and the stand frame may result. Vertical movement may only be undertaken in the extended state.

Connector tube of the colposcope



CAUTION

Risk of crushing due to a sudden lowering of the colposcope

The colposcope is heavy and can cause crushing injuries.

- ▶ Hold the colposcope when releasing the clamp nut and set it to the lowest position.



CAUTION

Risk of injury, damage to the device

If the connector tube is not inserted deep enough into the stand frame, personal injury or equipment damage may occur.

- ▶ The connecting tube of the colposcope must always be inserted **at least 20 cm** in the stand frame in order to ensure stability.

Prerequisite (for balance-o-matic stand):

- ▶ The balance-o-matic stand is in a locked position.
1. Hold the colposcope head firmly and loosen the clamp nut on the clamp head:

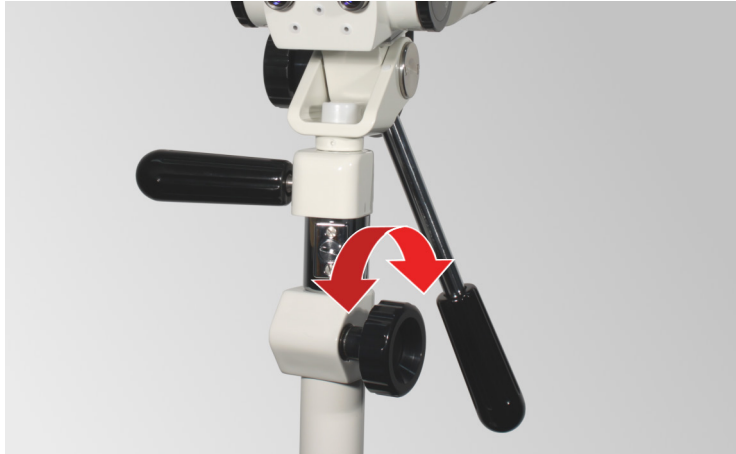

2. Move the colposcope to the desired height and tighten the clamp nut again. Please note the minimum insertion depth of 20 cm.
 - ▶ The general working height is set.

6.1.2 Performing a dioptric correction

Adjustment for near- or far-sightedness can be made at the two eyepieces. The adjustment can be made for each eye individually (range: +7 to -7 diopters):

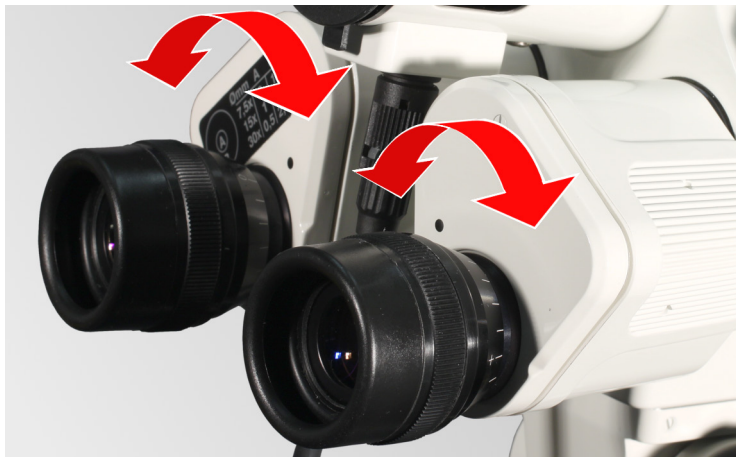

| | |
|---------------------|--|
| Emmetropia | Both eyepieces are set to 0 . |
| With glasses | Both eyepieces are set to 0 . |
| No glasses | The eyepieces are adjusted individually. |

The dioptric correction is made while setting the focus at the eyepieces (see section 6.1.4 *Adjusting focus of eyepieces*).

6.1.3 Using a colposcope with glasses

1. Remove the two upper eyepiece cups:



2. Continue as described in section 6.1.4 *Adjusting focus of eyepieces*.

6.1.4 Adjusting focus of eyepieces

1. Turn the horizontal adjustment so that the colposcope head is in the center position.
2. Position the colposcope horizontally at a distance of 300 mm and in front of an even object (such as a wall with patterns).
3. Set the magnification drum changer to the maximum magnification level 30x (15x for colposcopes with magnification levels 3.75x/7.5x/15x):



4. Turn the prism bodies so far apart that you can easily see the same image.

5. Set the diopter rings of both eyepieces to 0:



6. With your left eye, look through the left eyepiece. The two displayed concentric circles must be in focus. If this is not the case, turn the diopter ring until you can see the two circles sharp and clear.
7. Now turn the horizontal adjustment until you can clearly see the object with your left eye.
8. Then, look through only the right eyepiece with your right eye. Turn the diopter ring until you can clearly see the object with the right eye.
 - The colposcope is now set so that it is always in focus for both eyes and all magnification levels.
 - At the same time, a connected camera now also shows a sharp image on all magnification levels.

6.1.5 Setting up working distance

The working distance is 300 mm, measured from the front edge of the front lens up to the surface of the tissue.

Position the colposcope within this distance, before you begin working with the colposcope.

6.2 Using a colposcope



CAUTION

Risk of injury in the event of a faulty device

A faulty device can cause injuries.

- ▶ If it can be assumed that the device can no longer be operated safely, take it out of service, secure it against further use and contact your supplier.



We recommend that when not in use, the device is switched off and covered with the dust cover.

6.2.1 Performing fine adjustments

Fine adjustment drives

Both the fine adjustments in horizontal and vertical direction and the angle can be carried out via the two fine adjustment drives:



- | | |
|----------|--|
| 1 | Vertical adjustment Moves the colposcope head up and down (max. 80 mm). |
| 2 | Horizontal adjustment - Focus Moves the colposcope head back and forth (max. 40 mm). |
| 3 | Horizontal adjustment - Tilt The colposcope head can be tilted by raising or lowering the horizontal adjustment. |

6.2.2 Swing in the green filter

For a differentiated view of the tissue you can swing in the green filter:



- | | |
|---|---------------------------|
| 1 | Swing in the green filter |
| 2 | Swing out green filter |



Models with a 45° angular insight (1DW LED, 3MLW LED, 3MVCW USB LED) do not have a green filter.

6.2.3 Adjusting magnifications

The magnifications can be set via the magnification drum changer:



6.2.4 Determining the lesion size

There are two concentric rings integrated into the left eyepiece, an inner circle **A** and an outer circle **B**. With the help of these rings, the size of the observed object can be estimated. There is a legend on the left-hand prism body, which specifies the size of the two circle diameters in mm for each magnification level:



Please note that determining the lesion size is not a precise measurement method and is only a subjective assessment.

7 Care, maintenance, inspection

7.1 Care and disinfection

**WARNING****Injury through electric shock**

The power supply is not protected against ingress of water. The ingress of liquid can cause an electric shock.

- ▶ Always pull out the mains plug before cleaning the device.

Colposcope, stand**CAUTION****Damage to the device**

To avoid damage to the device, observe the following instructions for cleaning and disinfection:

Cleaning

- ▶ Regularly wipe the colposcope and stand with a damp (not wet) cloth. Use the cleaning solution in the normal dilution. Then dry the device with a dry, lint-free cloth. The following cleaning solutions can be used:
 - Universal cleaner
 - Hygiene cleaner
 - Surface cleaner

Disinfection

- ▶ Disinfect the device with common disinfectants in accordance with the applicable national hygiene standards and according to your internal hygiene plan. The following disinfectants can be used:
 - Ready-to-use alcohol-based disinfectant solution, e.g. 2-propanol (isopropanol)
 - Disinfectants based on amines, e.g. Chloramine-T
 - Disinfectants based on quats (quaternary ammonium compounds), e.g. dimethyldidecylammonium chloride
 - Disinfectants based on active oxygen (peroxide), e.g. oxygen releasing compounds.
- ▶ The cleaning and disinfectants have to be used according to the manufacturer's specifications observing the recommended exposure times.

Observe the following cleaning and disinfection instructions to avoid damage to the device:

- ▶ A soap solution can be used to clean the lenses. Cloths suitable for use with optical devices should be used for drying.
- ▶ Do not use any abrasive or aggressive cleaning agents or disinfectants, as they may cause damage and corrosion.

Optics



CAUTION

Damage to the optics

Cleaning and disinfection is carried out as with the colposcope and stand. To avoid damage to the optics, observe the following instructions for cleaning:

- ▶ An aqueous soap solution can be used for cleaning the optics. Special optical cloths are suitable for wiping dry.
- ▶ Never use strong or corrosive cleaning agents and disinfectants! They can damage the surface.

Power supply



WARNING

Injury through electric shock

The power supply is not protected against ingress of liquids. The ingress of liquid can cause an electric shock.

- ▶ Avoid dripping and splashing water to prevent damage to the device.
- ▶ Do not spray the power supply with cleaning agents or disinfectants.

Further components (photo/video adapter, photo equipment, cameras)



CAUTION

Damage to the device

To avoid damage to the device, observe the following instructions for cleaning:

- ▶ Observe the same instructions as listed under *Colposcope, stand and Optics*.
- ▶ Do not attempt to clean the lenses **inside** the adapter or camera! This can lead to damage to the devices.

7.2 Maintenance



Leisegang colposcopes are easy to care for, contain no wearing parts and require no calibration or preventive maintenance within the defined expected service life.

Before use, the devices should be checked by the user for visible damage. An inspection of electrical safety, in connection with a functionality test in accordance with the information provided by the standard IEC 62353, should be carried out after each repair and **at least every 3 years**. Specific functional tests are not defined.

Leisegang does not specify the test method to be used to test the electrical safety so that each of the methods shown in the aforementioned standard is permissible for the measurement of protection class II devices.

Since the colposcope has no application part and is not in direct contact with the patient, the limits for devices with a type B application part should be used for the assessment.

7.3 Inspection, repeat tests



Leisegang Feinmechanik-Optik GmbH recommends a regular inspection of the device every **3 years**. Please contact your supplier for further information.

8 Repair



- Repairs may only be carried out by authorized persons or organizations. In the event of a necessary repair, please contact your supplier.
- Send the device in a cleaned and disinfected condition. Please observe the information in chapter 7 *Care, maintenance, inspection*. Enclose written evidence of the cleaning and disinfection with the device.
- The device must be packed shock and shatter-proof. Use original packaging if possible.

9 Customer service

In case of technical problems, questions or complaints, please contact your supplier.

In case of complaints, always keep the following information at hand:

- Order number,
- Model number (**REF**) and
- Serial numbers (SN) of the components.

The serial numbers are found on the respective type plates:

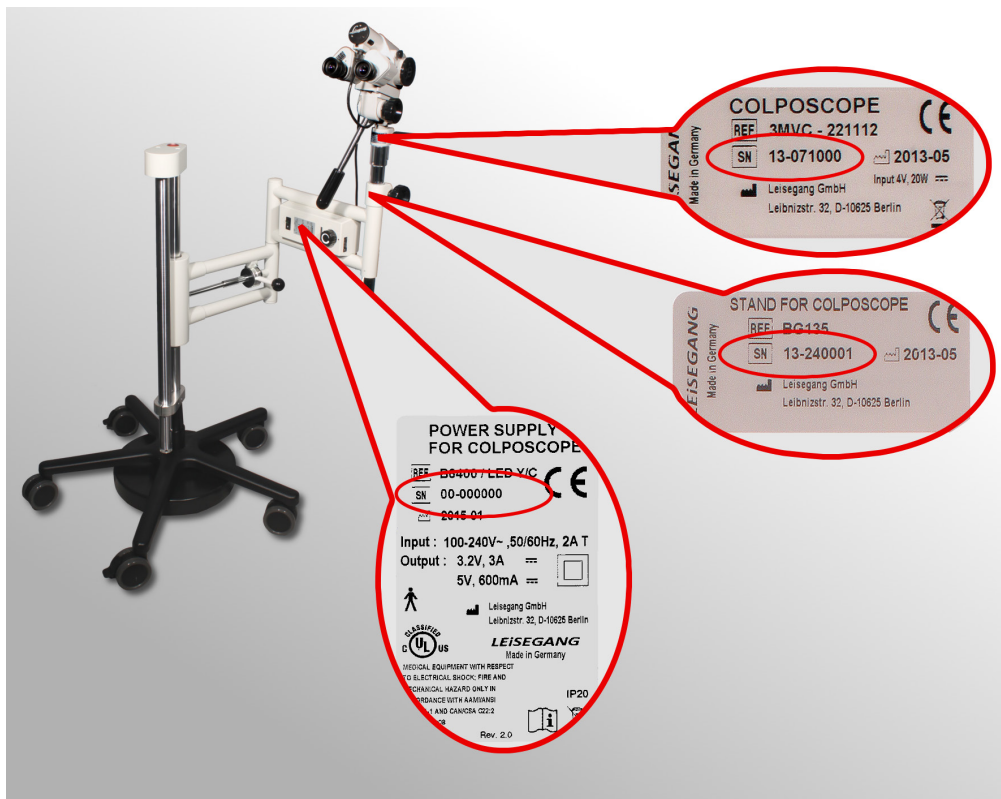

The type plates shown in the figures are examples!

10 Disposing of waste equipment



Countries of the European Union

According to the EU Directive on waste electrical and electronic equipment (WEEE) (2012/19/EU), waste electrical and electronic equipment must be disposed of separately. Therefore, do not dispose your old equipment with your normal household waste, but take it to your local collection site or contact your supplier.

Countries outside of the European Union

Other rules may apply in countries outside of the European Union, please note the regional regulations.

11 Glossary

| | |
|---|---|
| Dioptric correction | Compensation of short- or far-sightedness. These can be made individually for each eye using the two eyepieces (range: +7 to -7 diopters). |
| Working distance | Distance front lens to object level (= 300 mm). |
| Color temperature T_F | Specifies the color impression of a light source. Using color temperature, one can set the color of a light source in relation ('hot' or 'cold' light) with the color of natural light (sunlight). The unit of measurement for color temperature is Kelvin (K). |
| Light field diameter | The size of the field, which is illuminated at a distance of 300 mm. |
| Field of view diameter | The visible area of an object that can be seen through the colposcope. The greater the magnification level, the smaller the field of view and vice versa. |
| Green filter | A color filter that darkens red and blue light and brightens green light. Thus, the contrast of the image is increased, blood vessels are shown more clearly. |
| Intensity of Illumination E_v | Specifies the luminous flux from a light source onto a certain area. The unit of measurement for illumination intensity is lux (Abbrev.: lx). |
| LED | Light Emitting Diode. Electronic semiconductor device that emits light when an electrical current passes through. |
| Eyepiece | The optical portion facing towards the eyes, with which the enlarged image produced by the colposcope can be viewed. |
| Beam path, convergent | The two light beams for the eyes run together in a point that lies at a distance of 300 mm in front of the front lens. This distance is in accordance with the working distance. This way, the eye does not have to focus on this point on its own, as is the case with a parallel beam path, therefore fatigue-free work is ensured. |
| White Balance | White balance is used to calibrate the camera to the color temperature of the light at the location. This will ensure that the camera displays white - and thus all other shades - correctly. |

12 Keyword index

A

| | |
|------------------------------------|----|
| Adjusting focus of eyepieces | 33 |
| Adjusting magnifications | 36 |

C

| | |
|------------------------|----|
| Care | 38 |
| Clinical benefit..... | 6 |
| Complaint | 41 |
| Customer service | 41 |

D

| | |
|---------------------------|----|
| Device description | 12 |
| Dioptric correction | 32 |
| Disinfection..... | 38 |
| Disposal | |
| Old device | 42 |
| Packaging material | 29 |

E

| | |
|------------------------------------|----|
| Electromagnetic compatibility..... | 25 |
|------------------------------------|----|

F

| | |
|------------------------------|----|
| Fine adjustment drives | 35 |
|------------------------------|----|

G

| | |
|--------------------|----|
| Glossary | 43 |
| Green filter | 36 |

H

| | |
|------------------------|----|
| Height adjustment..... | 30 |
|------------------------|----|

I

| | |
|------------------|----|
| Inspection | 40 |
|------------------|----|

M

| | |
|--------------------|----|
| Maintenance | 40 |
| Model number | 24 |

O

| | |
|----------------|----|
| Operation..... | 30 |
|----------------|----|

P

| | |
|-----------------------------------|----|
| Patient population | 6 |
| Performance characteristics | 6 |
| Placement on the market | 10 |
| Precautions | 8 |

R

| | |
|--------------------------------------|----|
| Repair | 40 |
| Repeat tests | 40 |
| Reporting of serious incidents | 11 |

S

| | |
|---------------------------|---|
| Safety instructions | 7 |
|---------------------------|---|

T

| | |
|----------------------------|----|
| Technical data | 17 |
| Transport and storage..... | 29 |

U

| | |
|---------------------------------------|----|
| Using a colposcope with glasses | 33 |
|---------------------------------------|----|

W

| | |
|----------------------------|----|
| Warranty information | 10 |
| Working distance | 34 |

Visit our website for more information:



Issued by:

LEISEGANG Feinmechanik-Optik GmbH
Leibnizstrasse 32
D-10625 Berlin

Tel.: +49 30 319 009-0

Fax: +49 30 313 5992

E-Mail: sales.leisegang@coopersurgical.com

www.leisegang.de

Copyright © LEISEGANG Feinmechanik-Optik GmbH 2013-2021